

## BEHAVIOR OF BARE AND ASPIRATED THERMOCOUPLES IN COMPARTMENT FIRES

Linda G. Blevins

Advanced Fire Measurements Group  
National Institute of Standards and Technology  
100 Bureau Drive, Stop 8653, Gaithersburg, Maryland 20899-8653

*Keywords: Instrumentation, Radiation, Room Fires*

### ABSTRACT

As part of an effort to characterize the uncertainties associated with temperature measurements in fire environments, models of bare bead, single-shielded aspirated, and double-shielded aspirated thermocouples were developed and used to study the expected effects of varying the gas and average effective surroundings temperatures on the percent error in measured temperature of each type of thermocouple. The models indicate that thermocouples respond differently to changes in effective surroundings temperature in a hot upper layer than in a relatively cooler lower layer of a room fire. The use of an aspirated thermocouple reduces the error in the measurement, but does not eliminate it entirely. The present study is intended to provide fire researchers with a methodology for developing working models of thermocouples which are tailored to their own configurations.

### NOMENCLATURE

$A_i$  = Surface area of the innermost shield for double-shielded probe ( $m^2$ )  
 $A_o$  = Surface area of outermost shield for single- and double-shielded probes ( $m^2$ )  
 $C_{i \rightarrow o}$  = Geometric constant defined for double-shielded model  
 $D_b$  = Thermocouple bead diameter (m)  
 $h_{bU}$  = Convective heat transfer coefficient between external gas flow and bare thermocouple bead ( $W/m^2 \cdot K$ )  
 $h_{bu}$  = Convective heat transfer coefficient between aspirating gas flow and thermocouple bead for single- and double-shielded probes ( $W/m^2 \cdot K$ )  
 $h_{iu}$  = Convective heat transfer coefficient between central aspirating gas flow and innermost shield for double-shielded probe ( $W/m^2 \cdot K$ )

$h_{iw}$  = Convective heat transfer coefficient between annular aspirating gas flow and innermost shield for double-shielded probe ( $W/m^2 \cdot K$ )  
 $h_{oU}$  = Convective heat transfer coefficient between the external gas flow and probe for single- and double-shielded configurations ( $W/m^2 \cdot K$ )  
 $h_{ou}$  = Convective heat transfer coefficient between aspirating gas flow and shield for single-shielded probe ( $W/m^2 \cdot K$ )  
 $h_{ow}$  = Convective heat transfer coefficient between the annular aspirating gas flow and outermost shield for double-shielded probe ( $W/m^2 \cdot K$ )  
 $k_g$  = Gas thermal conductivity ( $W/m \cdot K$ )  
 $Nu$  = Nusselt number  
 $P$  = Percent error in measured temperature (%)  
 $Re$  = Reynolds number  
 $T_b$  = Thermocouple bead temperature (K)  
 $T_g$  = Gas temperature (K)  
 $T_i$  = Innermost shield temperature for double-shielded probe (K)  
 $T_o$  = Outermost shield temperature for single- and double-shielded probes (K)  
 $T_\infty$  = Average effective surroundings temperature (K)  
 $U$  = External fire-induced flow velocity (m/s)  
 $u$  = Aspiration velocity across thermocouple bead for single and double-shielded probes (m/s)  
 $w$  = Aspiration velocity in the annulus for double-shielded probe (m/s)  
 $\epsilon_b$  = Thermocouple bead emissivity  
 $\epsilon_i$  = Innermost shield emissivity for double-shielded probe  
 $\epsilon_o$  = Outermost shield emissivity for single- and double-shielded probes  
 $\nu_g$  = Gas kinematic viscosity ( $m^2/s$ )  
 $\sigma$  = Stefan-Boltzmann constant ( $5.67 \times 10^{-8} W/m^2 \cdot K^4$ )

## INTRODUCTION

Measuring temperature in and around fires is important for validating models and for gaining an empirical understanding of their very complex behavior. The most common way to measure temperature during fire testing is to use bare bead thermocouples. However, the temperature indicated by a bare bead thermocouple near an enclosure fire differs from the true gas temperature because the bead exchanges radiation with the room walls, the hot flame gases and soot, and the ambient environment through doors and windows. Radiation corrections are difficult to perform for several reasons. First, selecting an effective surroundings temperature is arduous because of the temporally and spatially varying environment. In addition, the local convection velocity and gas composition vary and are not usually known. The emissivity of the bead varies with temperature and with exposure to fire environments; soot can accumulate, changing the bead diameter and its thermophysical properties. Finally, convective heat transfer correlations are based on experiments and have high uncertainties (e.g., Whitaker, 1972). Because of these difficulties, fire researchers often perform experiments without considering radiation losses or gains on thermocouples. Jones (1995) showed that large errors in measured gas temperature are possible when these effects are neglected in fire testing.

One way to reduce the effect of radiation exchange on the measurement is to use an aspirated thermocouple, which consists of a thermocouple enclosed in one or more cylindrical radiation shields. The gas to be measured is pulled through the shields using a pump or other aspiration device. The shields reduce the radiation exchange between the thermocouple and its surroundings, while the rapid flow increases the convective exchange between the thermocouple and the gas. The result is that the temperature indicated by an aspirated thermocouple is closer to the true gas temperature than that indicated by a bare thermocouple bead of similar size.

While using an aspirated thermocouple favorably reduces the influence of radiation on the measurement, temporal and spatial resolution are sacrificed. In addition, aspirated thermocouples are cumbersome. For example, during a recent study at the National Institute of Standards and Technology (NIST), a rather large ice bath, two dry carbon dioxide traps, and two glass wool filters were necessary in each aspirated thermocouple sampling line to protect the vacuum pump and rotameter from water damage and soot clogging (Pitts *et al.*, 1999). This is especially constraining when many thermocouples are used simultaneously, which is generally desirable for fire studies. Because aspirated thermocouples involve tradeoffs in resolution and ease of use, the individual researcher must decide if the improvements offered by their use justify the extra effort to use them. The aim

of this paper is to describe engineering models developed to help researchers evaluate the effectiveness of aspirated thermocouples.

## BACKGROUND

Several papers have been published on the design of aspirated thermocouples, also known as suction pyrometers, for use in furnaces, gas turbines, and other practical combustors (Schack, 1939; Mulliken, 1941; Mulliken and Osborn, 1941; Land and Barber, 1954; Land, 1956; Baker *et al.*, 1961; Hills and Paulin, 1969; Chedaille and Braud, 1972; Magidey and Lysakov, 1975; Morillon and Perthuis, 1974; Khalil *et al.*, 1976; Wojtan and Jones, 1981; Goldman, 1987; Heitor and Moreira, 1993). Schack (1939) published a model based on steady-state thermocouple and shield energy balances for single- and double-shielded aspirated thermocouples. Constant convective heat transfer coefficients for internal and external convection to the probe surfaces and constant metal emissivities of 0.7 were assumed. Schack linearized the fourth-order temperature terms in small intervals of temperature, but the model was then limited to application in the pre-selected intervals. The modeling of Land and Barber (1954) employed the assumptions of constant convective heat transfer coefficients for all shields at a given aspiration velocity, negligible heat transfer by convection on the external surface of the probe, and differences between gas and surroundings temperatures of less than 200 K. The latter assumption allowed Land and Barber to linearize radiation heat transfer, with a heat transfer coefficient equal to  $\sigma T_g^3$ . The authors presented simplified charts and tables to guide designers of aspirated thermocouples for furnace environments.

The previously mentioned papers emphasized applications where (1) the temperature of the surrounding walls is lower than the temperature of the gas, and (2) the gas and surroundings temperature do not differ appreciably. In a room fire, which often consists of a relatively cool lower gas layer and a generally hot upper gas layer, these two conditions are not always satisfied. For example, in the lower layer, the effective surroundings temperature is higher than the gas temperature, and their difference can be very large. Thus, the behavior of aspirated thermocouples in fires might differ from that in practical combustors, and further work is warranted.

To the author's knowledge, Newman and Croce (1979) published the only study focusing on aspirated thermocouples for fire research. They developed a prototype aspirated thermocouple which featured a 1.8-mm-diameter thermocouple bead enclosed in a 6.4-mm-diameter steel shield. Their mathematical model consisted of nonlinear, steady-state energy balances on the bare bead, aspirated thermocouple bead, and shield, with varying convection coefficients. Combining

specific experimental results with their model equations, these authors demonstrated in various ways that the model adequately described the behavior of the aspirated thermocouple. The authors tested their instrument by increasing the flow through the probe until the measured temperature approached a value which was independent of aspiration velocity. Based on this technique, they concluded that an aspiration velocity of about 7 m/s was adequate to obtain a temperature "which should correspond to the true gas temperature." There is an intriguing difference between the study of Newman and Croce and previously published studies of aspirated thermocouples, which recommended using considerably higher aspiration velocities, for example, 60 m/s (Schack, 1939), 150 m/s (Land and Barber, 1954; Land, 1956), and 300 m/s (Khalil *et al.*, 1976). The contradiction in recommended aspiration velocities between the fire and practical combustor literature warrants further investigation to verify that 5 m/s to 10 m/s velocities are fast enough for accurate temperature measurement in fire testing. This is especially important because the American Society for Testing and Materials, in the Standard Guide for Room Fire Experiments (ASTM, 1995), recommends that the gas velocity within aspirated thermocouples be maintained near 5 m/s, stating that this is "sufficiently high to allow accurate temperature measurement based on thermocouple voltage alone, even within flame zones." Based on this recommendation, fire researchers routinely use probes with aspiration velocities of about 5 m/s (e.g., Steckler *et al.*, 1982; Lattimer *et al.*, 1994; Dembsey *et al.*, 1995).

The present research involves solution of steady-state, nonlinear aspirated thermocouple energy balance equations combined with convective heat transfer correlations from published literature. The present approach applies for a wider range of fire conditions than the models of Schack and Land and Barber. The model is an extension of the efforts of Newman and Croce, in that a parametric study is performed to investigate aspirated thermocouples in typical room fire conditions. Bare and single-shielded probes like those addressed by Newman and Croce are modeled in addition to double-shielded probes like those employed in a recent NIST study (Pitts *et al.*, 1999). The modeling allows an evaluation of the order-of-magnitude difference in recommended aspiration velocities between the fire and practical combustor literature.

The objectives of this paper are (1) to describe idealized models of bare bead and single- and double-shielded aspirated thermocouples, (2) to demonstrate that thermocouples behave differently in the upper and lower layers of a room fire, (3) to describe the ways that aspirated thermocouples reduce errors in room fire temperature measurements, and (4) to provide researchers with an approach for developing their own working models of aspirated thermocouples.

## MODEL DEVELOPMENT

The geometry of the double-shielded probe is depicted in Fig. 1. The single-shielded probe is identical to the probe shown in Fig. 1 with the inner shield removed, and the bare-bead thermocouple can be thought of as the instrument shown in Fig. 1 with both shields removed and no aspiration. The probe and bead sizes match those used in recent NIST experiments (Pitts *et al.*, 1999). The following assumptions are used in development of the models: (1) All surfaces are opaque, isothermal, diffusely emitting and reflecting, graybodies with constant emissivities. (2) Gases are radiatively non-participating. (3) Conduction through solids is negligible; shields are infinitely thin. (4) Radiation exchange through the tube openings is negligible. (5) Gas properties are temperature-dependent properties of air, calculated using polynomial expansions of tabulated properties (Incropera and DeWitt, 1990). (6) Heat is added or removed from the surroundings in an amount which allows them to remain at a constant effective temperature. (7) The gas temperature remains constant inside and outside of the probe, and is not affected by convective heat exchange with the probe. (8) There is an external crossflow in a direction perpendicular to the probe axis. (9) The thermocouple bead is convex, is completely enclosed in the innermost shield, and has a surface area much smaller than that of the inner shield. (10) The outermost shield is completely enclosed by the surroundings and has a surface area which is much smaller than that of the surroundings. (11) For the double-shielded probe, the inner shield is completely enclosed in the outer shield.

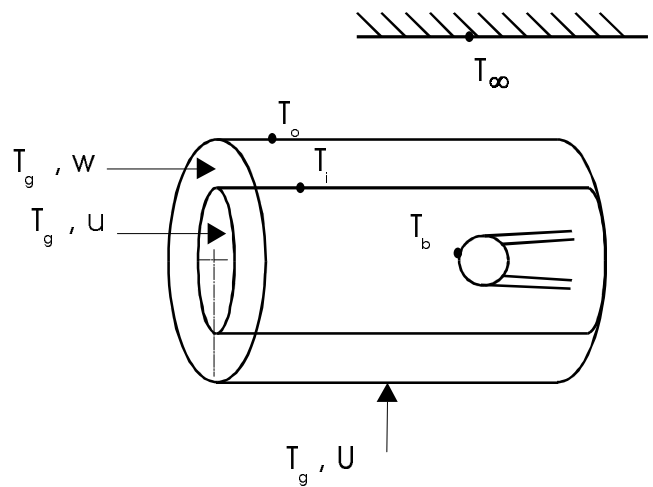

Figure 1 Schematic of double-shielded aspirated thermocouple.

The energy balance for the bare thermocouple bead with no shields or aspiration is

$$T_b^4 [\epsilon_b \sigma] + T_b [h_{bu}] - [\epsilon_b \sigma T_\infty^4 + h_{bu} T_g] = 0. \quad (1)$$

The thermocouple bead is modeled as a sphere in crossflow, and the convective heat transfer correlation recommended by Whitaker (1972) is used to evaluate  $h_{bu}$ . The uncertainty of the sphere Nusselt number is  $\pm 25\%$  (Whitaker, 1972).

For the single-shielded model, the thermocouple bead energy balance yields

$$T_b^4 [\epsilon_b \sigma] + T_b [h_{bu}] - [\epsilon_b \sigma T_o^4 + h_{bu} T_g] = 0. \quad (2)$$

The shield energy balance yields

$$T_o^4 [\epsilon_o \sigma] + T_o [h_{ou} + h_{ou}] - [\epsilon_o \sigma T_\infty^4 + (h_{ou} + h_{ou}) T_g] = 0. \quad (3)$$

The convective heat transfer coefficient between the aspirating gas and the shield,  $h_{ou}$ , is computed primarily using correlations for developing laminar and fully turbulent flow. For developing laminar flow, the Seider-Tate correlation for combined entry lengths (Eq. 20 in Whitaker, 1972) is used. This correlation yields Nusselt numbers accurate to within  $\pm 25\%$ . For turbulent flow, the correlation developed by Petukhov, Kirillov, and Popov, and modified by Gnielinski (Eqs. 8.62-8.63 in Incropera and DeWitt, 1990) is applied for a smooth tube. Nusselt numbers for turbulent pipe flow are accurate to within  $\pm 10\%$ . For the probe external flow, a cylinder-in-crossflow correlation (Eq. 7.57 in Incropera and DeWitt, 1990) is used to evaluate  $h_{ou}$ . The uncertainty in this Nusselt number based on cylinder diameter is  $\pm 25\%$ .

For the double-shielded probe, the bead energy balance yields an equation identical to Eq. (2) with  $T_o$  replaced by  $T_i$ . The outer shield energy balance is

$$T_o^4 [C_{i \rightarrow o} \sigma (A_i/A_o) + \epsilon_o \sigma] + T_o [(h_{ow} + h_{ou})] - [C_{i \rightarrow o} \sigma (A_i/A_o) T_i^4 + \epsilon_o \sigma T_\infty^4 + (h_{ow} + h_{ou}) T_g] = 0, \quad (4)$$

and the inner shield energy balance becomes

$$T_i^4 [C_{i \rightarrow o} \sigma] + T_i [(h_{iu} + h_{iw})] - [C_{i \rightarrow o} \sigma T_o^4 + (h_{iu} + h_{iw}) T_g] = 0. \quad (5)$$

The constant  $C_{i \rightarrow o}$  exists because the surface area of the inner

shield is not small compared to that of the outer shield, and is defined as

$$C_{i \rightarrow o} = \frac{1}{\frac{1}{\epsilon_i} + \frac{1 - \epsilon_o}{\epsilon_o} \left( \frac{A_i}{A_o} \right)}. \quad (6)$$

In the central region of the innermost shield, heat transfer coefficients are modeled using the methods described for the single-shielded thermocouple. In the annulus,  $h_{iw}$  and  $h_{ow}$  are assumed equal, and are calculated using the pipe flow correlations discussed above based on the annulus hydraulic diameter.

The above nonlinear algebraic equations are solved simultaneously for each configuration using first order Newton's methods. The calculations were performed for metal emissivities between 0.2 and 1.0. While the errors computed for the bare bead, single-shielded, and double-shielded thermocouples increased with increasing  $\epsilon$ , the relative trends between them did not change. Representative results for  $\epsilon = 0.8$  are presented in this paper. The external flow velocity was assumed to be  $U = 0.5$  m/s. The  $T_\infty$  used in the analysis represents the effective radiation temperature of the potentially multi-temperature surrounding environment. The discussions in this paper are limited to temperatures below  $T_\infty = 1400$  K because this is a reasonable estimate of the maximum effective surroundings temperature in an enclosure fire.

The percent error in measured temperature,  $P$ , used to evaluate a particular thermocouple's effectiveness, is defined as

$$P = 100\% \times \left| \frac{(T_b - T_g)}{T_g} \right|. \quad (7)$$

The governing equations were kept in dimensional form for the present study. While nondimensionalization minimizes the number of parameters to be varied when analyzing a problem, it proves to be difficult when equations have both fourth-order and first-order terms, and when heat transfer correlations depend on local conditions in a complex way. Keeping the model equations in dimensional form allows the present study to be focused on regions of room fires (upper and lower layers) which are physically identifiable using absolute values of the gas and surroundings temperatures.

## RESULTS AND DISCUSSION

Figure 2 depicts the percent error in the measured temperature predicted for a 1 mm bare bead thermocouple, as a function of  $T_\infty$ , for a few gas temperatures between 300 K and 1400 K. The region where  $T_g$  is higher than  $T_\infty$  is termed the "upper layer," recognizing that the region includes but is not limited to the conditions generally found in the upper layer of

a room fire. Similarly, the region where  $T_g$  is lower than  $T_\infty$  is termed the "lower layer." The ovals are printed on the figure to indicate that upper layer ( $T_g > T_\infty$ ) conditions generally occur on the left side of the graph and lower layer ( $T_g < T_\infty$ ) conditions occur on the right side. Figure 2 shows that a bare bead thermocouple behaves differently in the upper and lower layers of a room fire. In the upper layer, the percent error for a given  $T_g$  is relatively insensitive to  $T_\infty$ , decreasing gradually to zero as  $T_\infty$  approaches  $T_g$ . In this region, the percent error increases with increasing  $T_g$ . In contrast, in the lower layer, the percent error is a strong function of both  $T_g$  and  $T_\infty$ , increasing more and more rapidly with increasing  $T_\infty$  when the latter value is relatively high. In this region, the percent error decreases with increasing  $T_g$ . The behavior in both regions is controlled by the fourth order dependence of the radiation heat transfer rate on  $T_\infty$ . The most extreme errors occur in the lower layer when  $T_g$  is at its lowest assumed value (300 K) and  $T_\infty$  is at its highest (1400 K), which would most likely be encountered during a fully involved room fire.

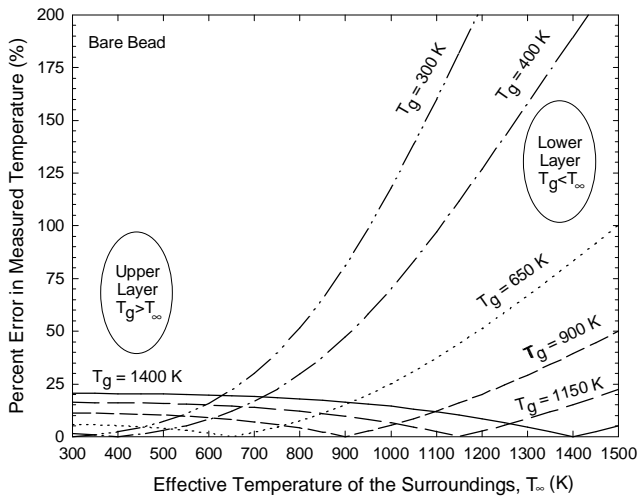

**Figure 2 Effect of surroundings temperature on the percent error in measured temperature for a bare bead thermocouple with diameter  $D_b = 1$  mm, emissivity  $\epsilon_b = 0.8$ , and external flow velocity  $U = 0.5$  m/s, with gas temperatures of 300 K, 400 K, 650 K, 900 K, 1150 K, and 1400 K.**

Figures 3 and 4 depict the predicted percents error in the measured temperature for the single- and double-shielded thermocouples with aspiration velocities equal to 5 m/s. Figure 3 demonstrates that the single-shielded probe behaves similarly to the 1 mm bare bead thermocouple, except the errors in the upper and lower layers are reduced for a given  $T_g$  and  $T_\infty$ , and the region of rapidly increasing error in the lower layer is shifted to higher  $T_\infty$ . This shift is expected to decrease

the likelihood that the region of high error will be encountered in an actual room fire test. This conjecture is based on the assumption that the likelihood that a thermocouple placed in the lower layer will experience a given  $T_\infty$  decreases as  $T_\infty$  increases to 1400 K and above. The figure shows that the percent error of the single-shielded thermocouple is bounded at about 12 % for  $T_g = 1400$  K in the upper layer, which compares with 20 % for the bare bead thermocouple. The trend is similar for the other gas temperatures. Thus, the single shield reduces the bare bead error to about half of its maximum value in the upper layer, and decreases the likelihood that large errors will occur in the lower layer.

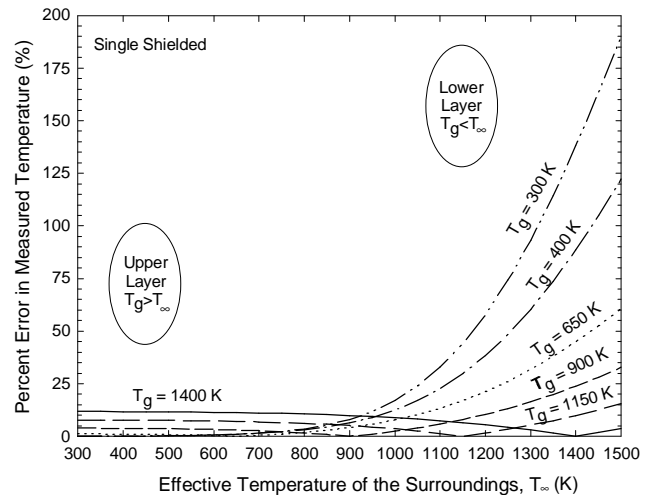

**Figure 3 Effect of surroundings temperature on the percent error in measured temperature for a single-shielded aspirated thermocouple, with bead diameter  $D_b = 1$  mm, shield diameter  $D_o = 8.6$  mm, emissivities  $\epsilon_b = \epsilon_o = 0.8$ , external velocity  $U = 0.5$  m/s, and aspiration velocity  $u = 5$  m/s, with gas temperatures of 300 K, 400 K, 650 K, 900 K, 1150 K, and 1400 K.**

Figure 4 shows that the double-shielded thermocouple behaves similarly to the single-shielded thermocouple, except that errors in the upper and lower layers are reduced further, and the region of rapidly increasing error in the lower layer is shifted to even higher  $T_\infty$ . This shift dramatically decreases the likelihood that extreme errors will occur in the lower layer, since the shift is toward unrealistically high  $T_\infty$  for typical room fires. For the double-shielded probe, the upper layer error is bounded at 6 % for  $T_g = 1400$  K, compared to 12 % for the single shield and 20 % for the bare bead. Thus, the double-shielded probe represents a significant improvement over the single-shielded probe, both in the upper layer where the error bound is decreased to half of the single-shield value, and in the lower layer where errors are reduced and the likelihood of occurrence of large error is lessened. The improved

performance of the double-shielded probe results primarily from better radiation shielding. In summary, aspirated thermocouples work in the upper layer by reducing errors, and in the lower layer by reducing errors and shifting the region of rapidly increasing error to unrealistically high average effective surroundings temperatures. It is important to note aspirated thermocouples reduce but do not eliminate errors.

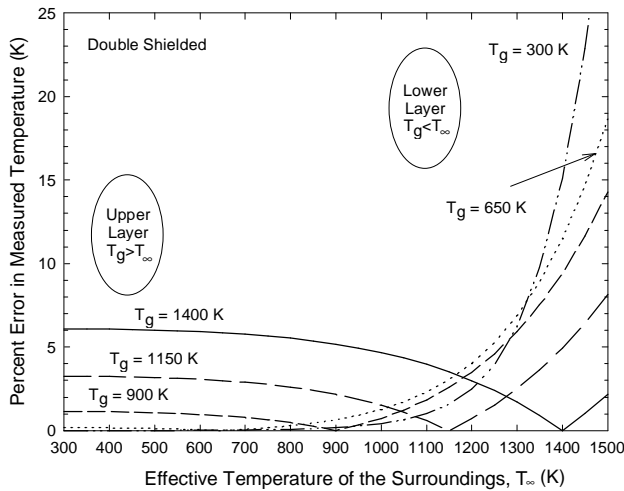

**Figure 4** Effect of surroundings temperature on the percent error in measured temperature for a double-shielded aspirated thermocouple, with bead diameter  $D_b = 1$  mm, inner shield diameter  $D_i = 5.6$  mm, outer shield diameter  $D_o = 8.6$  mm, emissivities  $\epsilon_b = \epsilon_i = \epsilon_o = 0.8$ , external velocity  $U = 0.5$  m/s, and aspiration velocity  $u = w = 5$  m/s, with gas temperatures of 300 K, 650 K, 900 K, 1150 K, and 1400 K.

The results presented in this section reveal that lower layer thermocouple errors are generally very sensitive to  $T_\infty$  for a given  $T_g$ . A small change in a fire can hence cause a very large change in the temperature indicated by a lower layer thermocouple. Even aspirated thermocouples are susceptible to this radiation effect. It is worth mentioning that the  $T_\infty$  experienced by a thermocouple in any region of an enclosure fire generally increases as the fire grows. Hence, lower-layer thermocouple errors are likely to be low initially but increase in magnitude as time (and fire growth) progresses. Near flashover, room fire conditions change so rapidly that application of the present (or any other) models becomes extremely difficult.

One benefit of solving the types of equations developed here is that unusual data trends can be explained. For example, thermocouples used at floor level in the doorway of an enclosure should indicate ambient temperature since there is no preheat mechanism for the incoming air (Steckler, *et al.*, 1982). However, bare thermocouples used in these

locations often indicate temperatures higher than room temperature (Steckler, *et al.*, 1982; Luo, 1997). Considering that lower layer thermocouples are very susceptible to radiation errors of the type depicted on the right side of Fig. 2, this experimental result is not surprising.

Figure 5 depicts solutions to the Land and Barber (1954) equations for a 1 mm bead inside a single shield with a aspiration velocity of 5 m/s. The darkened lines mark the regions where  $T_g$  and  $T_\infty$  are within 200 K of each other, which are the regions for which Land and Barber developed their model. Comparison of Fig. 5 with Fig. 3 clearly shows that the linearized model is incorrect when  $T_g$  differs significantly from  $T_\infty$ . In particular, the Land and Barber model severely overestimates the error in the upper layer, and does not capture the region of rapidly increasing error in the lower layer. This detail is emphasized here because while the Land and Barber charts and tables are convenient design tools for practical combustors, they should be used with caution by fire researchers, since the modeling on which they are based does not apply for all possible fire conditions.

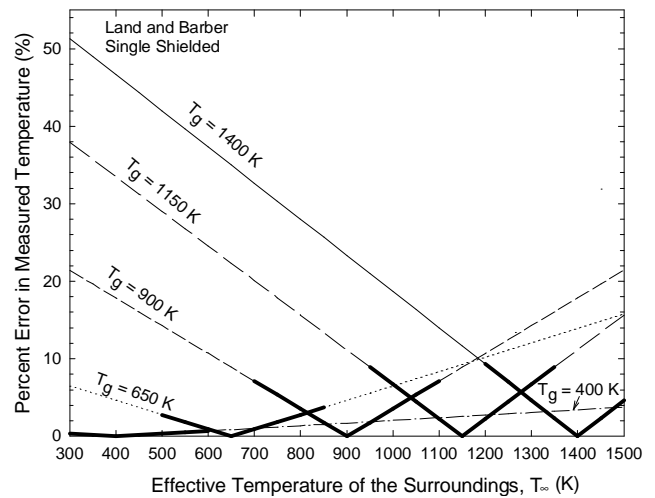

**Figure 5** Effect of surroundings temperature on the percent error in measured temperature predicted using the Land and Barber model for a single-shielded aspirated thermocouple, with bead diameter  $D_b = 1$  mm, shield diameter  $D_o = 8.6$  mm, emissivities  $\epsilon_b = 0.8$ ,  $\epsilon_o = 1.0$ , no external gas flow, and aspiration velocity  $u = 5$  m/s, with gas temperatures of 400 K, 650 K, 900 K, 1150 K, and 1400 K. The darkened lines represent the regions where  $T_g$  and  $T_\infty$  differ by less than 200 K.

To demonstrate the role of aspiration velocity on the effectiveness of single- and double-shielded aspirated thermocouples, Fig. 6 depicts their predicted response to

changes in this velocity for the upper-layer case when  $T_g$  and  $T_\infty$  are 1200 K and 300 K, respectively, and for the lower-layer case when these values are 300 K and 1200 K, respectively. These cases were selected because they represent reasonable values for the maximum temperature differences in a room fire. For the upper-layer case, as soon as aspiration is applied, the temperatures increase suddenly from their no-aspiration values of 720 K to 1030 K for the single-shielded and to 1130 K for the double-shielded probe. The temperatures then rise gradually as the velocity is further increased. For the lower-layer case, as soon as aspiration is applied, the temperatures drop from their no-aspiration values of 1130 K to 900 K for the single-shielded and to 500 K for the double-shielded thermocouple. The single-shielded temperature then drops gradually as the velocity is further increased. The double-shielded temperature drops rather abruptly to a value very near  $T_g$ . The reason for this difference in behaviors between the single- and double-shielded probes in the lower layer is that the selected  $T_g$  and  $T_\infty$  fall within the region of rapidly increasing error in the lower layer for the single-shielded probe, but this behavior has been shifted to higher  $T_\infty$  for the double-shielded probe.

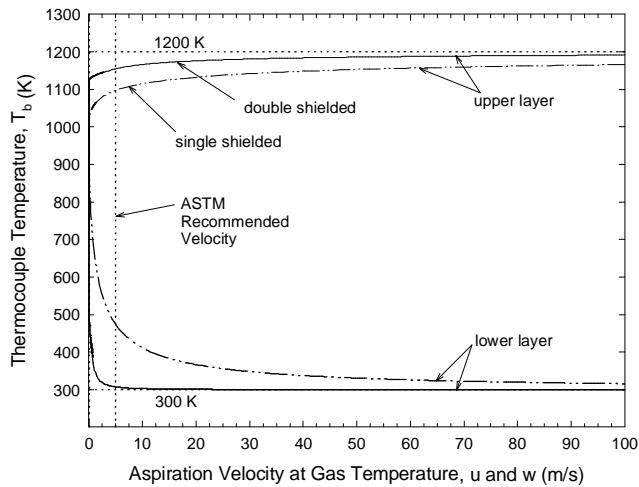

**Figure 6 Predicted aspirated thermocouple response to variation in aspiration velocity. Upper layer predictions are based on an assumed gas temperature of 1200 K and an assumed surroundings temperature of 300 K. Conversely, lower layer predictions are based on an assumed gas temperature of 300 K and an assumed surroundings temperature of 1200 K.**

One important result from Fig. 6 is that the practical combustor literature is correct in its assertion that the use of very high aspiration velocities (on the order of 100 m/s) reduces the error of an aspirated thermocouple. However, removing the large quantities of gas necessary to achieve

aspiration velocities of 100 m/s is not, in general, practical for fire testing. The most striking result shown in Fig. 6 is that, under certain conditions, the error associated with the use of an ASTM recommended single-shielded aspirated thermocouple probe with an aspiration velocity of 5 m/s can be very large. For the specific example in the figure, the 5 m/s aspiration velocity produces an error of 60 % in the lower layer and 10 % in the upper layer. Increasing the velocity to 20 m/s decreases these errors to 20 % and 5 %, respectively; further increase to 100 m/s decreases them to 5 % and 3 %.

## CONCLUSIONS

Heat transfer models were developed for bare bead, single-shielded aspirated, and double-shielded aspirated thermocouples. A parametric study which involved varying the gas and effective surroundings temperatures for a set of thermocouples with specified geometry, assumed internal and external gas velocities, and fixed emissivities, was performed. The study revealed that thermocouples behave differently in the upper and lower layers of a room fire. In the upper layer, for a given gas temperature, the percent error in a thermocouple measurement is relatively insensitive to surroundings temperature. In the lower layer, much larger errors which increase rapidly with surroundings temperature are possible. The most extreme errors occur in the lower layer when the gas temperature is at its lowest (300 K) and the surroundings temperature is at its highest (1400 K).

While the absolute values of the percents error presented here depend strongly on the configurations studied and the model assumptions, the relative trends between the different instruments allow general conclusions to be drawn. Aspirated thermocouples reduce the magnitude of the errors in the upper and lower layers of a room fire and reduce the likelihood that large errors will occur in the lower layer. Double-shielded designs perform better than single-shielded designs of similar outer diameter. For the present configurations, the single-shielded probe reduces the percent error in the measured temperature to half of its bare bead value in the upper layer. The double-shielded probe reduces the percent error by half again in this region. In the lower layer, the single-shielded probe, in addition to generally reducing errors, shifts the region of large error to higher surroundings temperatures, and the double-shielded probe shifts the largest errors to surroundings temperatures which are unrealistically high for typical room fire conditions. These shifts reduce the likelihood that large errors will occur in the lower layer. To the author's knowledge, the differences between thermocouple behavior in the upper and lower layers of a room fire noted in this paper, along with the explanations offered for the behavior of aspirated thermocouples in fire environments, have not been reported previously.

It is emphasized that the individual experimenter must decide what errors are tolerable before selecting thermocouples for fire testing. The use of an aspirated thermocouple reduces the error, but does not eliminate it entirely. Researchers must understand the limitations of both bare bead and aspirated thermocouples. For example, the assertion in the ASTM standard that an aspiration velocity of 5 m/s is "sufficiently high to allow accurate temperature measurement" will not be correct in all cases. The present study provides researchers with the understanding necessary to develop engineering models of bare bead and aspirated thermocouples, tailor them to their own needs, and use them side-by-side with experiments to assess potential measurement errors.

## ACKNOWLEDGMENTS

The author acknowledges William Pitts, Emil Braun, Erik Johnsson, Richard Peacock, and Paul Reneke for contributing to discussions which provided motivation for this modeling.

## REFERENCES

- ASTM, 1996, ASTM Standard E 603-95a "1996 Annual Book of ASTM Standards," ASTM Publication Code 01-040796-10, West Conshohocken, PA, p. 589.
- Baker, H.D., Ryder, E.A., and Baker, N.H., 1961, "Temperature Measurements in Engineering," Wiley, New York, p. 328.
- Chedaille, J., and Braud, Y., 1972, "Industrial Flames, Volume I, (Beer, J.M., and Thring, M.W., Eds.), Crane, Russak, and Co., Inc., New York, p. 14.
- Dembsey, N.A., Pagni, P.J., and Williamson, R.B., 1995, "Compartment Fire Near-field Entrainment Measurements," *Fire Saf. J.*, Vol. 24, pp. 383-419.
- Goldman, Y., 1987, "Temperature Measurement in Combustors by Use of Suction Pyrometry," *Combust. Sci. and Tech.*, Vol. 55, pp. 169-175.
- Heitor, M.V., and Moreira, A.L.N., 1993, "Thermocouples and Sample Probes for Combustion Studies," *Prog. Energy Combust. Sci.*, Vol. 19, pp. 259-278.
- Hills, A.W.D., and Paulin, A., 1969, "The construction and calibration of an inexpensive microsuction pyrometer," *J. Sci. Instrum.*, Vol. 2, pp. 713-717.
- Incropera, F.P., and DeWitt, D.P., 1990, "Fundamentals of Heat and Mass Transfer (3<sup>rd</sup> ed)", Wiley, New York.
- Jones, J.C., 1995, "On the Use of Metal Sheathed Thermocouples in a Hot Gas Layer Originating from a Room Fire," *J. Fire Sci.*, Vol. 13, pp. 257-260 (1995).
- Khalil, M.B., E.-Mahallawy, F.M., and Farag, S.A., 1976, "Accuracy of Temperature Measurements in Furnaces," *Letters Heat Mass Transfer*, Vol. 3, pp. 421-432.
- Land, T., 1956, "Suction Pyrometry," *Instrum. Autom.*, Vol. 29, pp. 1314-1320.
- Land, T., and Barber, R.B., 1954, "The Design of Suction Pyrometers," *Trans. Society of Instr. Techn.*, Vol. 6, pp. 112-130.
- Lattimer, B.Y., Ewens, D.S., Vandsburger, U., and Roby, R.J., 1994, "Transport and Oxidation of Compartment Fire Exhaust Gases in an Adjacent Corridor," *J. of Fire Prot. Engr.*, Vol. 6, pp. 163-181.
- Luo, M., "Effects of Radiation on Temperature Measurement in a Fire Environment," *J. Fire Sci.*, Vol. 15, pp. 443-461 (1997).
- Magidey, P.L., and Lysakov, I.I., 1975, "Corrections of Local Values of Flame Temperature Measured by Suction Pyrometers," *Heat Transfer-Sov. Res.*, Vol. 7, pp. 154-160.
- Morillon, R., and Perthuis, E., 1974, "Pyrometres a aspiration: Principes. Realisation d'instruments miniaturises," *Rev. Gen. Therm.*, Vol. 149, pp. 399-410.
- Mulliken, H.F., 1941, "Gas-temperature Measurements and the High-Velocity Thermocouple," in *Temperature: Its Measurement and Control in Science and Industry*, Reinhold, New York, p. 775.
- Mulliken, H.F., and Osborn, W.J., 1941, "Accuracy Tests of the High-Velocity Thermocouple," in *Temperature: Its Measurement and Control in Science and Industry*, Reinhold, New York, p. 805.
- Newman, J.S., and Croce, P.A., 1979, "A Simple Aspirated Thermocouple for Use in Fire," *J. Fire Flammability*, Vol. 10, pp. 327-336.
- Pitts, W.M., Braun, E., Peacock, R.D., Mitler, H.E., Johnsson, E.L., Reneke, P.A., and Blevins, L.G., 1999, "Thermocouple Measurement in a Fire Environment," NIST Internal Report (to appear).
- Schack, A., 1939, "The Theory and Application of the Suction Pyrometer," *J. Inst. Fuel* Vol. 12, pp. S30-S38.
- Steckler, K.D., Quinter, J.G., and Rinkinen, W.J., 1982, "Flow Induced by Fire in a Compartment," NIST Internal Report No. 82-2520.
- Whitaker, S., 1972, "Forced Convection Heat Transfer Correlations for Flow in Pipes, Past Flat Plates, Single Cylinders, Single Spheres, and for Flow in Packed Beds and Tube Bundles," *AIChE J.*, Vol. 18, pp. 361-371.
- Wojtan, M.S., and Jones, K.A.G., 1981, "Improvements in the design and operation of a suction pyrometer," *Meas. Control*, Vol. 14, pp. 301-305.